

High-Speed RS-232/RS-485/RS-422 Single-Mode Fiber Optic Modem User's Manual

MODEL 277SM

1.0 Description:

The MODEL 277SM was designed to provide the most versatile connection possible between any asynchronous serial equipment using Fiber Optic cable. It allows any two pieces of asynchronous serial equipment to communicate full or half-duplex over two fibers at typical distances up to 20KM. The converter can also be set up in "Repeater" mode to create a multi-drop master/slave configuration, allowing one serial device to talk to multiple slave devices around a fiber ring.

RS-232 data signals at up to 115.2K bps and RS-422, or RS-485 data signals at up to 115.2K bps are supported. Different standards can be mixed and matched to allow RS-232 devices to connect to your RS-422 or RS-485 system. This means the MODEL 277SM can replace converters and isolators when connecting remote devices, while providing the EMI/RFI and transient immunity of optical fiber.

The MODEL 277SM supports both the Transmit and Receive data lines, and provides full hardware control of the RS-422/485 driver with automatic Send Data Control circuit. Timeouts are dip-switch selectable between 0.10 and 2.2 ms. All serial connections are provided on the same DB-25 female connector, while the multimode fiber is connected via two ST connectors. The unit is powered by 9VDC at 140 mA max.

2.0 RS-232 Connections:

Connection of the MODEL 277SM is simple and straight forward. The DB-25 female serial connector is used for connecting to either RS-232, RS-422 or RS-485. The RS-232 signals are pinned as a DCE device (input on Pin 2 and output on Pin 3). A straight through cable can be used from

your DB-25 port on any DTE device such as a PC or terminal. A standard 9 to 25-pin adapter can be used in cases where the serial port on the DTE device is a DB-9. A null modem cable or adapter that swaps pins 2 and 3 is needed for connecting to modems or other DCE devices. See Figure 1 for connection diagrams to 9 pin and 25 pin DTE and DCE devices. Because RS-422 and RS-485 signals are also available on the same connector, take special care not to hook any external signals to these pins. This is not a problem for most serial devices, but a custom cable must be made that does not connect to the extra pins on the DB-25 connector if your device has power or special non-standard outputs.

Figure 1: RS-232 Connection Diagrams

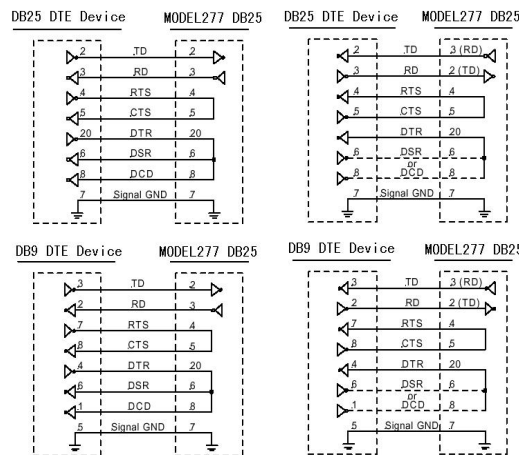

3.0 RS-422 & RS-485 Connections:

The RS-422/485 driver and receiver are connected to 4 pins on the DB-25 connector. Signal ground is on Pin 7. When connecting to a four-wire RS-422/485 device or system, connect the output of your device to pins 16 (B or +) and 17 (A or -). Connect the input to your device to pins 14 (B or +) and 15 (A or -). For two-wire RS-485 systems, the driver and receiver of the MODEL277SM must be connected together by tying pins 14 and 16 together and 15 and 17

together. This allows the MODEL277SM to communicate half-duplex over the same pair. Refer to Figure 2 for connection diagrams to your RS-422 or RS-485 equipment.

If termination is needed, a spot on the PCB of the MODEL277SM labeled Rt allows you to solder in a termination resistor across the RD(A) and RD(B) lines.

RS-422/RS-485 Connection Diagrams

DB-25 Female (PIN)	RS-422/RS-485
14	TD(B)+ T+
15	TD(A)- T-
16	RD(B)+ R+
17	RD(A)- R-

Figure 2: RS-422/485 Connection Diagrams

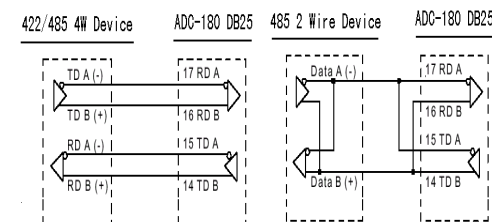

4.0 Fiber Optic Connections:

The MODEL277SM uses a separate LED emitter and photo-detector operating at 1310nm wavelength. Connections to the emitter and detector are on ST type connectors. Almost any multimode glass fiber size can be used including 50/125 μm, 62.5/125 μm, 100/140 μm, and 200 μm. One fiber is required for each connection between a transmitter and receiver. In a point-to-point configuration, two fibers are required between the two modems, one for data in each direction. A multi-drop ring configuration requires one fiber between TX and RX around the loop. See Figure 3 for typical point-to-point and multi-drop configurations.

The most important consideration in planning the fiber optic link is the "power budget" of the fiber modem. This value represents the amount of loss in dB that can be present in the link between the two modems before the units fail to perform properly. This value includes line attenuation as well as connector loss. For the MODEL277SM the typical

connector-to-connector power budget is 13 dB. Because 62.5/125 μm cable typically has a line attenuation of 0.6 dB per Km at 1310 nm, the 12 dB power budget translates into 20 KM. This assumes no extra connectors or splices in the link. Each extra connection would typically add 0.5 dB of loss, reducing the possible distance by 166 m (547 ft.). The actual loss should be measured before assuming distances.

Figure 3: Typical USE

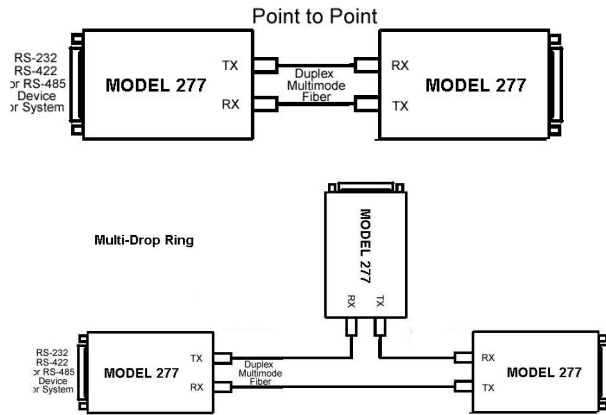

5.0 DIP-Switch Setup:

The Dip-Switch (SW1) on the MODEL277SM defines the mode of operation when being used for RS-422 or RS-485. Positions 1 through 6 on the switch determine the timeout of the RS-485 driver. Because the driver is controlled by hardware, a specific time must be set to tell the hardware how long to wait for data on the fiber side before turning off, the RS-422/485 driver. If this time is set too short, the driver could be disabled before transmission is complete, resulting in data corruption. If the time is set too long, the RS-485 device may respond before the RS-422/485 driver in the MODEL277SM is disabled, corrupting this response. We recommend that the timeout be set for approximately one

character time or longer. The character times for several different baud rates are selectable on switch positions 1 through 6. If you need a different timeout than what is provided, R1 can be removed and replaced with a different value R0. Table 1 shows the different timeout values for the switch positions as well as some typical R0 replacement values.

Positions 7 and 8 of SW1 determine when the RS-422/485 driver and receiver are enabled. Position 7 controls the driver and Position 8 controls the receiver. For RS-422 operation, set both switches to the “Off” position. For multi-drop RS-485 four-wire systems, position 7 should be “On” and position 8 should be “Off.” This allows the receiver to be enabled all of the time and eliminates some possible timing problems. For RS-485 two-wire systems, both switches should be in the “On” position. This disables the RS-422/485 receiver whenever the driver is enabled, preventing data from being echoed back to the fiber side of the MODEL277SM. Table 2 illustrates the switch settings for typical setups.

6.0 Multi-Drop Operation:

A multi-drop configuration is created by forming a ring of MODEL277SM. Each transmitter is tied to the following converter’s receiver, starting at a master node and continuing around to each slave and back to the master. By setting JP1 (on PCB Mainboard) to the “1-2” position on the slaves, “2-3” position on the Master, all data sent from the master or preceding slaves is echoed back out the fiber transmitter to the rest of the slaves and eventually back to the master node. Because all data is echoed back, there are special considerations when constructing a multi-drop system. The master will see its own transmitted data. This means that the master device must be full-duplex (RS-232, RS-422, or four-wire RS-485) and that it must be capable of ignoring or otherwise accepting its own echoed transmission. Slaves must also be able to accept data from previous slaves in the loop.

Table 1: 422/485 Switch Settings

	Position 7 TX Enable	Position 8 RX Enable
RS-485 2-Wire Mode (half duplex)	ON	ON
RS-485 4-Wire Mode (full duplex)	ON	OFF
RS-422 Mode (full duplex)	OFF	OFF

Table 2: RS-485 Timeout Selection

Baud Rate	Pos.1	Pos.2	Pos.3	Pos.4	Pos.5	Pos.6	R0
1200	ON	OFF	OFF	OFF	OFF	OFF	820k
2400	OFF	OFF	OFF	OFF	OFF	ON	N/A
4800	OFF	OFF	OFF	OFF	ON	OFF	N/A
9600	OFF	OFF	OFF	ON	OFF	OFF	N/A
19.2k	OFF	OFF	ON	OFF	OFF	OFF	N/A
38.4k	OFF	ON	OFF	OFF	OFF	OFF	N/A
57.6k	ON	OFF	OFF	OFF	OFF	OFF	N/A
76.8k	ON	OFF	ON	ON	OFF	OFF	N/A
115.2k	ON	ON	ON	OFF	OFF	OFF	N/A
153.6k	ON	OFF	OFF	OFF	OFF	OFF	6.2K
230.4k	ON	OFF	OFF	OFF	OFF	OFF	4.3K
460.8k	ON	OFF	OFF	OFF	OFF	OFF	2K

7.0 Specifications:

Transmission Line: Dual Single-mode optical cable

Point to Point Transmission: Asynchronous, half or full-duplex

Multi-Drop Transmission: Asynchronous, half duplex, master/slave, ring

Interfaces: RS-232, RS-422, or RS-485

Data Rates: RS-232 0 to 115.2Kbps
RS-422/485 0 to 115.2K

Distance:RS-485/RS-422 0-1.2KM

Typical Range: Up to 20 KM on Singlemode glass fiber

Coupled Power Budget: 12.1 dB

Optic Wavelength: 1310 nm

Connectors: DB-25 female for serial connection, ST connectors for fiber

Power Supply: Requires 9 – 14 VDC @ 250 mA max.

Dimensions: 6.3”L x 4.3”W x 1.25”H